

SECTION B-B

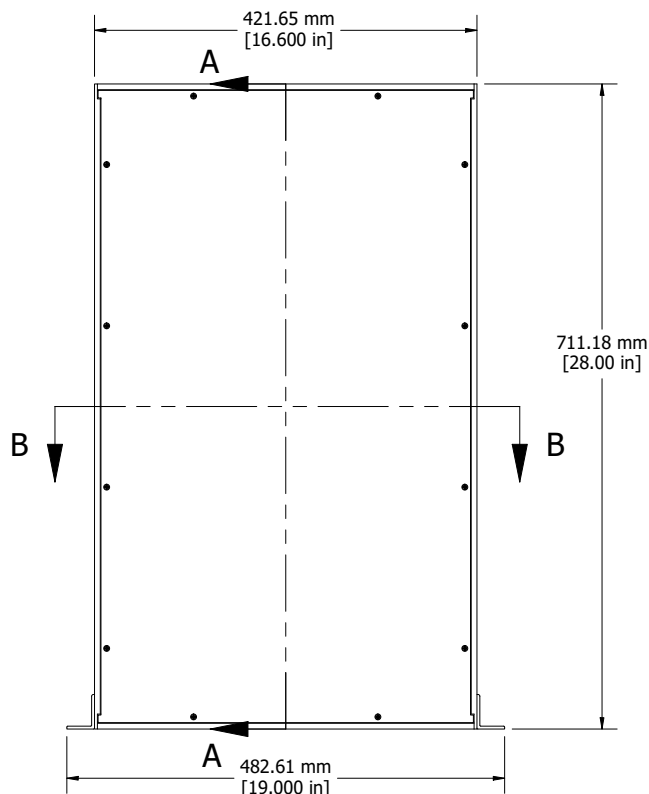

ASSEMBLY - TOP VIEW

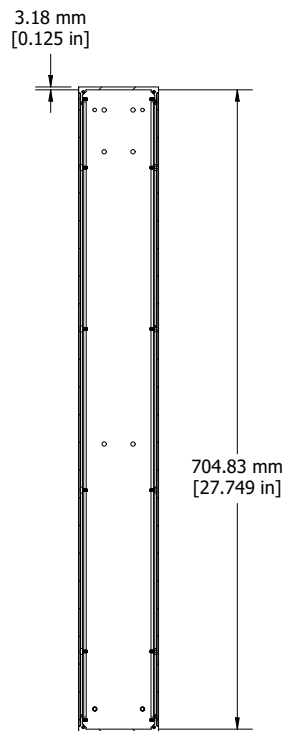

SECTION A-A

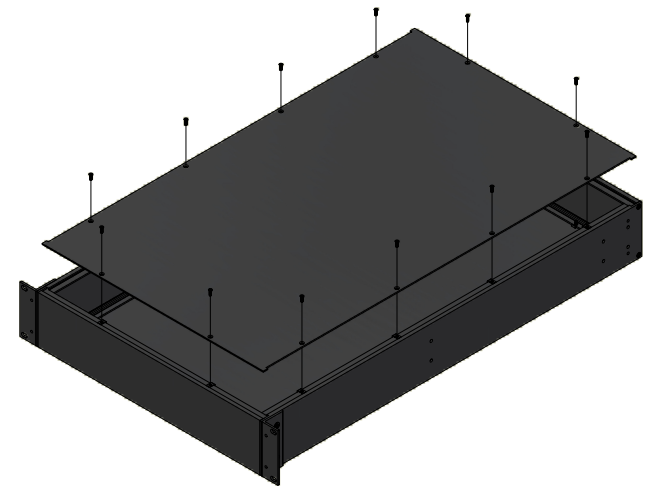

EXPLODED ISOMETRIC VIEW

Enclosures can be Factory Modified (Milling, Drilling, Printing etc.)
 Contact Factory - mjm@hammondmfg.com for quotes
 Solid models of this enclosure available in STEP or IGES.

RM2U1928SBK

| | |
|--|--|
| Extruded Aluminum Frame - Type 6063 | |
| 2 Panels - .064" Aluminum (5052-H32) Powder Coat | |
| 2 Mounting Brackets - .125" Aluminum | |
| 24 Screws - Flat Head 4-40 x 3/8" | |
| 8 Screws - Counter Sunk Head 6-32 x 3/8" | |
| 4 Screws - Counter Sunk Head 10-32 x 3/8" | |
| 24 Nuts - #4 Speed Nuts | |
| Four Self Adhesive Rubber Feet - 1421T3 | |

ACCESSORIES

| | |
|------------------|------------|
| PULL HANDLES | 1427E1BK |
| REAR BRACKET KIT | RM2U18BRKT |

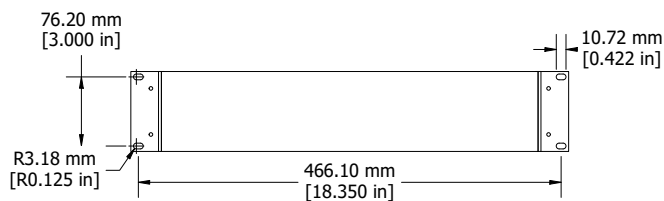

ASSEMBLY - FRONT VIEW

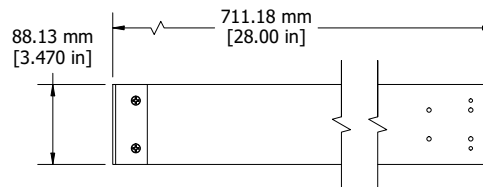

ASSEMBLY - SIDE VIEW



**HAMMOND
 MANUFACTURING™**

RM2U1928SBK

www.hammondmfg.com