

REV	ECN	DESCRIPTION	DATE	ENGR	CHK'D
A	N/A	RELEASED	AUG 22/17	AH	

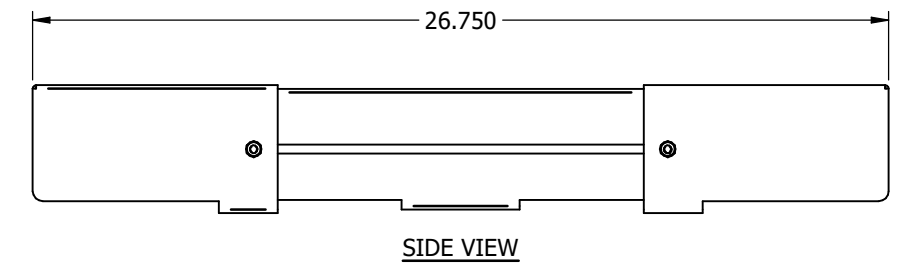
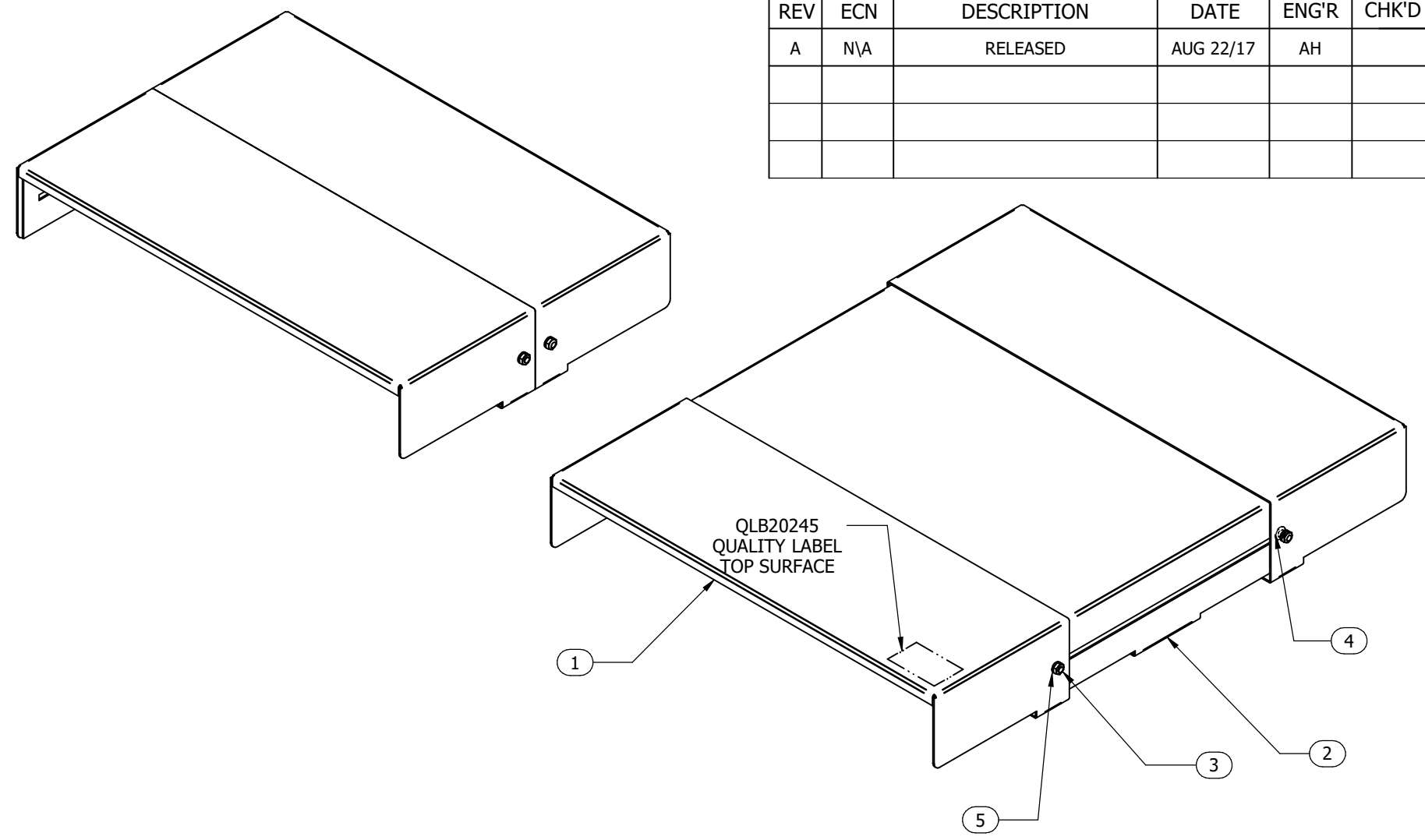
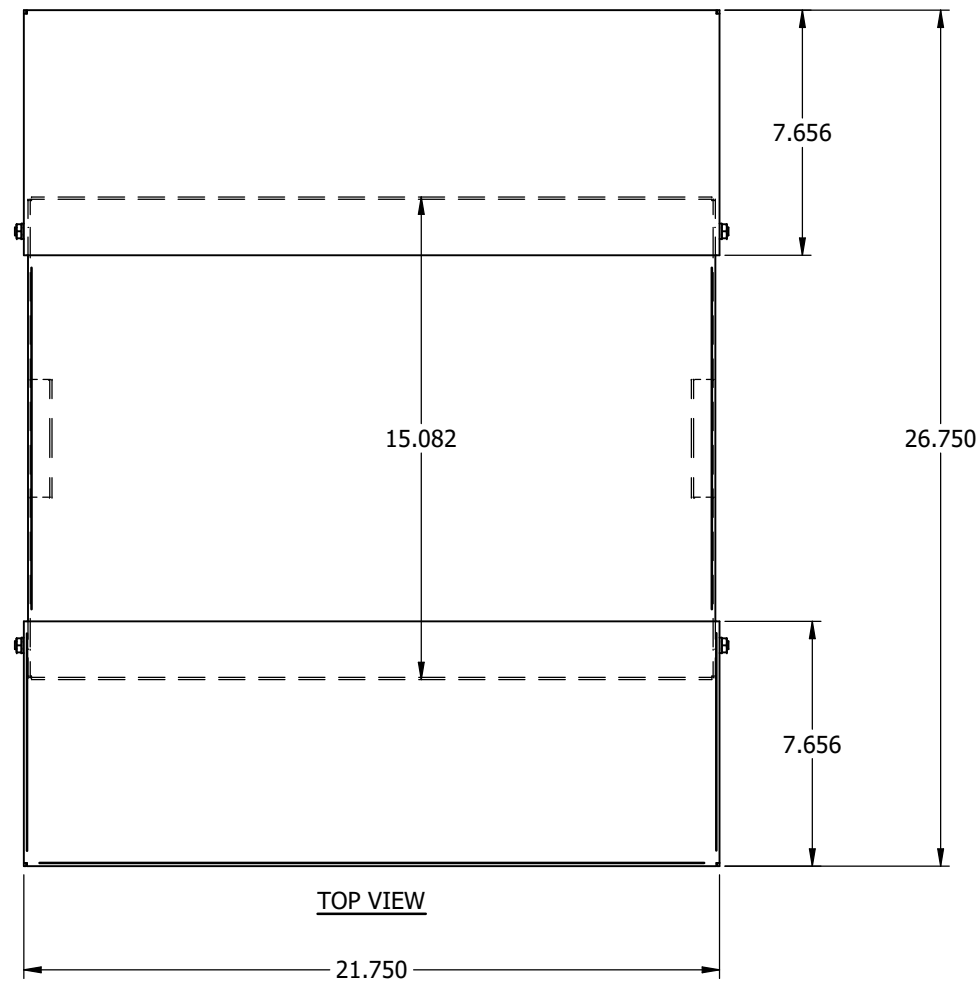

- NOTES - UNLESS OTHERWISE SPECIFIED:
1. REMOVE ALL BURRS AND SHARP EDGES.
 2. FINISH: PAINTED BLACK (BK2)

Item Number	Document Number	Title	Quantity
1	SR1702607-1	28 TO 39 ADJ SHELF END	2
2	SR1702607-2	28 TO 39 ADJ SHELF CENTER	1
3	NTS165305	NUT 1/4-20 HEX ZP	4
4	SCS19496	SCREW 1/4-20 X 1/2 CARR. BOLT	4
5	WAL25180	1/4 SPLIT LOCK WASHER	4

UNLESS OTHERWISE SPECIFIED
ALL DIMENSIONS ARE SHOWN IN INCHES.

TOLERANCES - UNLESS OTHERWISE INDICATED:

DIMENSION	UNDER 6"	6" TO 24"	OVER 24"	OVER 48"
FRACTION	± 1/32"	± 3/64"	± 1/16"	± 1/8"
.XX	± 0.04"	± 0.05"	± 0.06"	± 0.13"
.XXX	± 0.020"	± 0.020"	± 0.020"	± 0.030"
HOLE Ø	± 0.005"			
ANGLE	± 1°			

DWN	icaloian	SHEET SIZE	B
DATE	22-Aug-17		
CHK.			
AUTH.			
MAT'L	SEE COMPONENTS		
CAD DATA ONLY: DO NOT MANUALLY UPDATE			

N/A	SR1701650	PART No. SR1702607
MODIFIED FROM	NEXT ASSEMBLY	
HAMMOND MANUFACTURING CO. LTD Enclosure Group		
THIS DRAWING IS PROPRIETARY INFORMATION OF HAMMOND MFG. CO. LTD. NOT TO BE USED WITHOUT EXPRESSED WRITTEN PERMISSION OF HAMMOND MFG. CO. LTD.		
TITLE: ADJUSTABLE BOTTOM SHELF 28" TO 39"		
SCALE: 1:6	DWG: SR1702607	SHEET: 1 OF 1