

MATERIAL: SAE1050-1065
 HARDNESS: N/A
 HEAT TREATMENT: AUSTEMPER 40-45 R/C
 FINISH: ZINC PLATED

REV	ECN	DESCRIPTION	DATE	ENG'R	CHK'D
A	N/A	RELEASED	NOV 03-21	SD	PB

FOR USE WITH 0.064" TO 0.105" PANEL THICKNESS

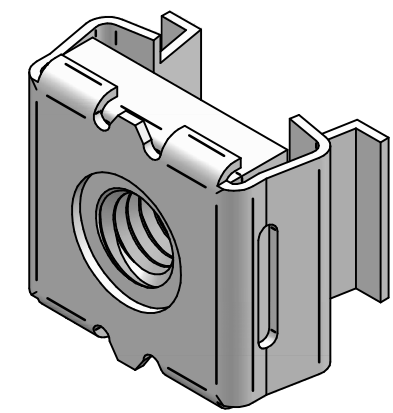
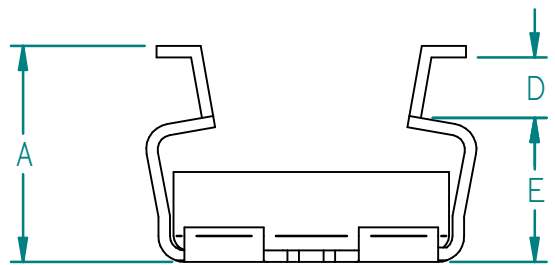

ISOMETRIC VIEW

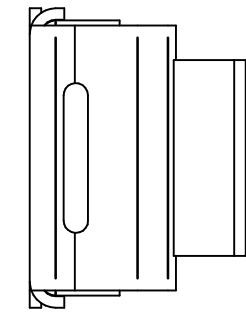
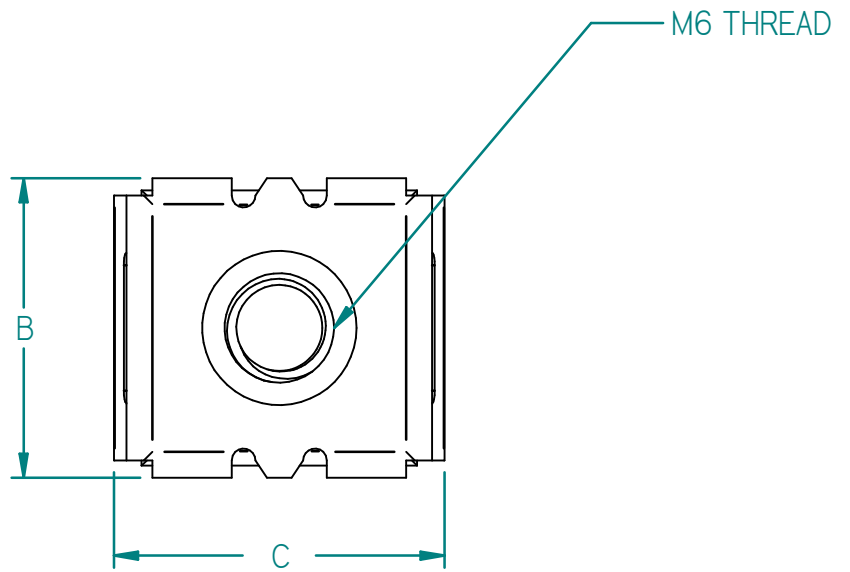

*NOTES: ALL DIMENSIONS ARE IN MM
 IMAGES ARE FOR ILLUSTRATION PURPOSE ONLY
 DATA SUBJECT TO CHANGE WITHOUT NOTICE

A	9.7
B	13.2
C	13.7
D	3.3
E	6.4

UNLESS OTHERWISE SPECIFIED
 ALL DIMENSIONS ARE SHOWN IN INCHES.

DIMENSION	TOLERANCES - UNLESS OTHERWISE INDICATED			
	UNDER 6"	6" TO 24"	OVER 24" TO 48"	OVER 48"
FRACTION	± 1/32"	± 3/64"	± 1/16"	± 1/8"
.XX	± 0.04"	± 0.05"	± 0.06"	± 0.13"
.XXX	± 0.025"	± 0.020"	± 0.020"	± 0.030"
HOLE	± 0.005"			
ANGLE	± 1°			

DWN	sdai
DATE	3-Nov-2021
CHK.	
AUTH.	
MAT'L	
CAD DATA ONLY: DO NOT MANUALLY UPDATE	

n/a	n/a	PART No. CAGNUTM6
MODIFIED FROM	NEXT ASSEMBLY	
HAMMOND MANUFACTURING CO. LTD Enclosure Group		
THIS DRAWING IS PROPRIETARY INFORMATION OF HAMMOND MFG. CO. LTD. NOT TO BE USED WITHOUT EXPRESSED WRITTEN PERMISSION OF HAMMOND MFG. CO. LTD.		
TITLE: CAGE NUT		
SCALE: 3:1	DWG: NTS18096	SHEET: 1 OF 1