

Operating- and Installation Instructions

DTS

Keep This Manual With Air Conditioner

Contents

1 Unpacking and Handling.....	3
2 General Information.....	3
3 Technical Data and ID Plate.....	3
4 Application and Function.....	4
5 Installation instructions.....	5
6 Installation instructions, recessed mounting frame (optional).....	6
7 Start-up and operation.....	6
8 Maintenance.....	7
9 Shutdown.....	8
10 Warranty Policy.....	9
11 Applicable Standards and Regulations.....	10
12 Trouble-Shooting.....	11
Sales Organisations.....	12

! WARNING !

Read this manual thoroughly before you attempt to install or test the air conditioner.

1 Unpacking and Handling

Burr caused by production may be present on the metal edges of the unit. Always wear protective gloves when carrying out maintenance work and installation.

Before and while you are unpacking the Enclosure Air Conditioner, you have to conduct a visual inspection to determine whether the equipment has suffered any damage during transport. Please pay close attention to loose parts, dents, scratches, visible signs of oil loss, etc.

Any damage must be reported without fail to the transport carrier and not to Pfannenberg Inc. (follow the Warranty policy, item 10).

Before disposing of the packing material, make sure that it does not contain any loose components.

To facilitate warranty-claim settlement, please supply us with precise details of the defect (with photo, if possible) together with details of model designation and the unit serial number.



Do not place the unit directly on the floor as otherwise the condensate drainage connection may be damaged.

In order to protect it against damage, the equipment may only be transported and stored in its normal upright position. Failure to observe this instruction will render the provisions of this warranty null and void.

2 General Information

In the event that is necessary to transport the complete enclosure with Air Conditioner attached, we recommend that you detach the Air Conditioner and transport it separately. When handling the unit, please grip only the housing or the housing frame. Any work necessary on the unit may only be carried out by a suitable qualified specialist. Compliance with applicable safety and environmental regulations is imperative.

The Air Conditioner contain neither silicone compounds, PCB, PCT, asbestos, formaldehyde, cadmium nor anti-wetting substances.

Every unit is checked to ensure that it is tight according to the provisions of UVV-VGB 20.

We hereby declare that, prior to leaving the factory, the unit was subjected to an electrical safety check. This means that, in accordance with UVV-VBG 4, §5 (4), the operating company is released from the obligation to arrange for a test of the electrical part of the unit before taking the equipment into operation for the first time.

3 Technical Data and ID Plate

When carrying out installation and maintenance work, observe the data printed on the ID plate located on the right-hand side of the Air Conditioner . The technical details applicable to the unit are marked in supplement.

4 Application and Function

The Air Conditioner are designed to abduct heat from sealed switch cabinets. Any other use shall be deemed as a deviation from the design use.

The units operate according to the principles of a heat pump with two airflow circuits mutually isolated by mechanical means. The "internal airflow circuit" draws off heat from the electrical and electronic components into the Air Conditioner. The thus heated air is cooled and dehydrated inside the cooling unit and then blown back into the switch cabinet interior.

The "external airflow circuit" makes use of the ambient air to cool the condenser and thus expel the system's inherent heat into the atmosphere.

The fan in the "internal airflow circuit" is always in operation whenever voltage is applied to the Air Conditioner. The thermostat in this circuit regulates the compressor and the fan in the "external airflow circuit".

The air conditioner has been provided with an internal condensation removal system (depending on the model, supplements). The enclosure air is drawn across the evaporator pipes, it is cooled and dehumidified before it is blown back into the enclosure. The condensation has been removed from the air and the ambient air stream evaporates. The heat of the condenser pipes aids this evaporation.

Although the unit has been designed to remove the small amount of the condensation that will develop due to air infiltration into the sealed enclosure, care must be taken to provide the proper drainage for the overflow drain of the air conditioner. An overflow may occur if the air conditioner is operated for a period of time with the enclosure unsealed, allowing moisture laden ambient air to enter the evaporator section.

If water is found to be draining continuously from the overflow drain during normal operating, this means that a significant quantity of moisture laden outside air is entering the enclosure. Care should be taken to seal the enclosure against such infiltration.

CAUTION :

Any effective cooling operation can produce condenser water. Therefore, the Air Conditioner should only be fitted to sealed enclosures and only operated with closed doors.

We recommend that you install a contact switch on the door of the enclosure to cut out the cooling unit whenever the enclosure door is opened.



5 Installation Instructions

WARNING: To avoid possible personal injury or property damage when the Air Conditioner is to be mounted on door of cabinet, be sure that hinges will support the added weight of Air Conditioner. Also be certain Air Conditioner does not over-balance the electronic cabinet causing it to tip over when the door is opened. Weight of the unit can be found on the ID plate. Use all mounting holes to insure stability and efficient seal.

It is not necessary to remove the unit cover prior to installing the unit or setting it into operation. The unit is operable immediately after applying the operating voltage.

- 5.1 Place the drilling template included in the scope of supply onto the outside installation surface of the enclosure.
- 5.2 Drill the holes, and cut out the openings required for air transfer.

CAUTION:
Prevent steel filings from entering the switch cabinet.

- 5.3 Drive two stud bolts, included in the accessories, into both upper fixing points next to the notice sticker with the instructions of the depth, at the backside of the unit.
- 5.4 Place sealing strips around the cutouts of the enclosure.
- 5.5 Thread power and control leads through the air supply opening into the enclosure.
- 5.6 Suspend the cooling unit on the enclosure by using the stud bolts.
- 5.7 Affix the cooling unit from the inside of the enclosure using the M6 bolts included in the accessory package.

CAUTION:
The sealings have to be pressed to a thickness of 2mm / 0.08 inch.

- 5.8 Connect the cooling unit to the power supply.
- 5.9 An additional 5-core signal line is supplied on several units (circuit diagram, supplement) and is used for wiring a door contact and floating contact that opens whenever certain faults occur (e.g. excessive pressure in the cooling system, power failure, cable breakage in the signal line). Max. load on contact: 5A.



CAUTION:
Both mains voltage and frequency must correspond to the ratings printed on the cooling unit's ID plate. Work on electrical systems may only be carried out by qualified personal, who are to observe the applicable safety regulations.

6 Installation Instructions, recessed mounting frame (optional)

- 6.1 Place the drilling template included in the scope of supply on the outside surface of the enclosure to which you intend to attach.
- 6.2 Drill the holes, and cut out the openings.

CAUTION:

Prevent steel filings from entering the switch cabinet.

- 6.3 Place the mounting frame in the cutout and fix it in place using the washers and nuts supplied.
- 6.4 Fix the Air Conditioner in place in the mounting frame; see the installation in-structions, items 5.3 to 5.8 .

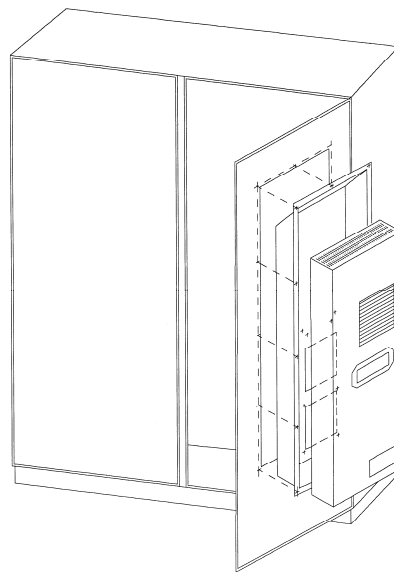

7 Start-up and Operation

As soon as the Air Conditioner has been successfully installed and connected to the electric supply, it may be set into operation. The ambient air must have a minimum temperature of +8°C / 46°F to operate the Air Conditioner correctly.



CAUTION:

As soon as the operating voltage is applied, the fan in the "internal airflow circuit" begins to turn.

The thermostat is preset at the factory at approx. +35°C / 95°F, i.e. the compressor and the fan in the "external airflow circuit" are not cut in until the temperature of the indrawn air exceeds this value. The overlap is fixed at approx. 4 K.



CAUTION:

When the unit is cut in, the fan in the "external airflow circuit" begins to turn.

8 Maintenance

- Before commencing with any maintenance and/or cleaning work on the Air Conditioner, disconnect it from the electrical power supply.
- Do not place the unit directly on the floor as otherwise the condensate drainage connection may be damaged.
- Apart from the occasional cleaning required on the condenser/ evaporator assembly, the unit is virtually maintenance-free. The cleaning interval depends entirely on the operating conditions (air pollution) and should be determined by the user.
- You can clean the condenser/ evaporator either with a soft-bristled brush, compressed air or, especially if it accumulates oily residues, with a high-pressure cleaner. Please do not use any pointed or sharp-edged objects.

When cleaning, make sure that you do not press against the louvres or damage them in any other way.

- **Filter:** The filter mat has to be cleaned (and, if necessary, replaced) at regular intervals to be determined by the operating company solely in accordance with ambient conditions (degree of air pollution).

Avoid wringing out the filter mat or aiming powerful jets of water at it!

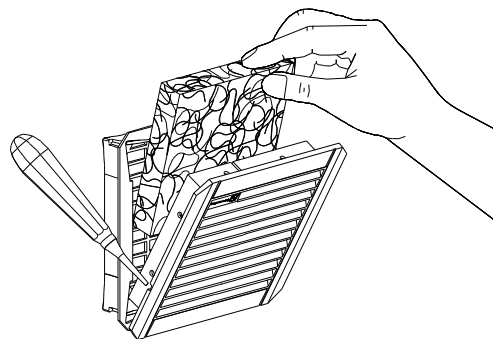

You can rinse the filter mat out using water heated to 40°C and commercially available mild detergent. It is possible to remove any dry dirt by knocking it out, vacuum cleaning it or blowing it out.

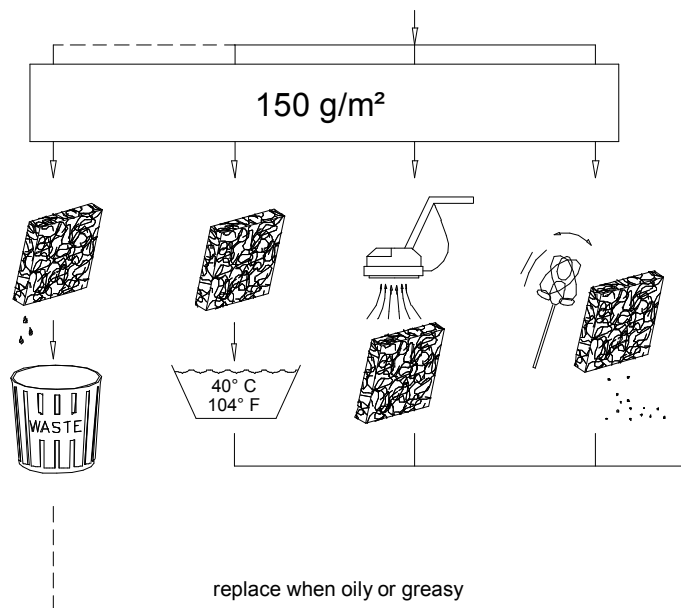

- **Compressor:** The compressor requires no maintenance. It is hermetically sealed, properly lubricated at the factory and should provide long time of satisfactory operating service.
- **Fans:** Blower motors require no maintenance. All bearings, shafts, etc. are lubricated during manufacturing for the life of the motor.

CAUTION:

Operation of the Air Conditioners in areas containing airborne caustics or chemicals can rapidly deteriorate filters, condenser coils, blowers and motors, etc. Contact Pfannenbergl Inc. for special recommendations.

- **Refrigerant Loss:** The Air Conditioner was carefully tested before leaving the factory to insure against refrigeration leaks. Leaks may require repair and recharging of the system. This work should be qualified professionals only, generally available in any reputable air conditioning repair or service company in your local area.

Refer to the data on your ID plate which specifies the type of refrigerant and the charge size in ounces.

Before recharging, make sure there are no leaks and that the system has been properly evacuated by deep vacuum.

Please be advised: In accordance with Section 608 of the Clean Air Act, no person maintaining, servicing, repairing, or disposing of appliances may knowingly vent or otherwise release into the environment any class I or II substance used as refrigerant.

- **Thermostat Control:** The thermostat controls the compressor and condenser fan which starts the cooling cycle. The evaporator fan will operate at all times as long as power is supplied to the unit.

All units equipped with thermostats leave the factory set at 35°C / 95°F.

CAUTION:

Operation with lower settings might cause higher quantities of condensate.

Proper use of the equipment for its intended purpose includes regular checks and appropriate maintenance.

9 Shutdown

Should the cooling unit not be required for a protracted period, you only need to disconnect it from the power supply. Protective measures must be adopted to ensure that unauthorized persons are unable to tamper with the unit and restart it.

If the unit is to be scrapped, disposal must be carried out by a competent person in accordance with the current regulations pertaining to environmental protection.

10 Warranty Policy

Pfannenbergl Inc. warrants that all material and workmanship are free of defects in quality which impair the usefulness of the Air Conditioner for a period of five (5) years for non-operating parts, except for the filter; for 2 ½ years for the air moving devices, and for one (1) year for the hermetic system components when installed and operated under the following conditions:

- 1 Voltage variation no greater than $\pm 10\%$ from ID plate rating.
- 2 Frequency variation no greater than ± 3 Hz from ID plate rating.
- 3 Ambient temperature must not exceed 52°C / 125°F.
- 4 Maximum cooling capacity not to exceed (BTU/HR) rating, including any heat sink, as indicated on the ID plate.
- 5 The unit must not be restarted for a period of three (3) minutes after international or accidental shut-off.
- 6 Compliance to all other installation, maintenance and operating instructions, as supplied.

Pfannenbergl Inc. assumes no liability beyond the repair or replacement of its own product, returned transportation prepaid.

This warranty does not cover:

- Labor or reimbursement for labor for removal or installation of any warranted part, except at a Pfannenbergl Inc. facility
- Use of equipment for other than its designed purpose or operating conditions
- Operation in harsh, oily, corrosive or other abnormal environmental conditions, without the proper filtration, sealing, protective coatings and/or weather protection
- Damage to hermetic system resulting from continuous operation with dirty / clogged air filters
- Use of refrigerant other than designated
- Customer modification or abuse
- Shipping damage or other accident
- Any and all conditions resulting from noncompliance with the preceding operating conditions

Should any part prove defective within the above warranty period, the customer may return the defective air conditioner that is under warranty to Pfannenbergl Inc. for repair at no charge. If return for repair is required a Return Authorization Number must be obtained.

Please contact Pfannenbergl Inc. for detailed information.

Pfannenbergl Inc. assumes no liability beyond the repair or replacement of its own product. Customer modification of any Pfannenbergl Inc. product voids this warranty.

The purchaser assumes the responsibility of grounding the unit and installing it in accordance with local electrical and safety codes, as well as the National Electric Code (NEC) and OSHA.

This express warranty constitutes the entire warranty with respect to the PRODUCT and IS IN LIEU OF ALL OTHERS, EXPRESS OR IMPLIED, INCLUDING ANY WARRANTY OF MERCHANTABILITY AND WARRANTY OF FITNESS FOR A PARTICULAR PURPOSE AND IN NO EVENT IS Pfannenbergl Inc. RESPONSIBLE FOR ANY CONSEQUENTIAL DAMAGES OF ANY NATURE WHATSOEVER.

11 Applicable Standards and Regulations

The Air Conditioner were developed, designed, installed and subjected to final inspection in accordance with the following European and North American standards and regulations:

SA 10300	UL / cUL file number
DIN EN 292	Safety of machinery, devices and systems
DIN EN 294	Safety of machinery
DIN EN 60 204-1	Electrical equipment for industrial machines
EN 55 014	Radio interference and its effect on electrical appliances
EN 50 081-2	Electromagnetical compatibility
EN 50 082-2	Electromagnetical compatibility
EN 60 335	Safety of electrical appliances
prEN 814-5	Air conditioners; switch cabinet cooling units
UVV-VBG 4	Electrical systems and machinery
UVV-VBG 20	Refrigeration systems
DIN 3168	Switch cabinet cooling units
DIN 8975	Technical requirements pertaining to the safety of refrigeration systems
DIN 31 001	Safety devices
DIN 45 635	Measuring noise levels at machinery
89/392/EEC	Machine Directive
91/368/EEC	
93/44/EEC	
93/68/EEC	
89/336/EEC	EMC Directive
91/263/EEC	
92/31/EEC	
93/68/EEC	
72/23/EEC	Low Voltage Directive
93/68/EEC	

12 Trouble-Shooting

If the Air Conditioner should require service, we have compiled a trouble-shooting chart to assist your service personnel. If additional assistance is required contact Pfannenberg Inc.

Problem	Possible Cause(s)	Solution
Unit not cooling	No Power	Check Power Source and Electrical Connections
	Loss of Refrigerant	Locate and repair leak
	Evaporator or Condenser Fan not operating	Replace motor, Capacitor or entire Assembly
	Filter clogged	Clean or replace Filter
	Dirty Evaporator or Condenser	Clean Device
	Thermostat improperly set	Lower setting until unit starts
	Thermostat defective	Replace Thermostat or Relay
	Failed Compressor	Replaced Compressor
Ice on Evaporator Coil	Insufficient Heat Load or Unit Oversized for Application	Contact Pfannenberg Inc.
	Failed Evaporator Fan	Replace Evaporator Fan Motor or Assembly
	Dirty Evaporator	Clean Device
Condensate draining continuously	Enclosure not properly sealed	Check and seal all openings
	Excessive opening of Enclosure	Eliminate the frequency of door opening
	Thermostat improperly set	Setting on 35°C / 95°F
Condensate fails to drain off	Malfunction on condensate overflow	Clean overflow and/or check that hose is connected without kinks
Excessive vibration	Defective Fan	Replace Fan
	Compressor Loose	Tighten Mounting Bolts
Compressor Inoperative	Low line Voltage	Check Nameplate Voltage
	Loss of Compressor Oil	Replace Compressor
	Loss of Refrigerant	Locate and repair leak
	Failed Compressor Capacitor	Replace Capacitor
	Thermal Overload	Contact Hammond Manufacturing
	Power interruptions	Allow Compressor time to reset
Refrigerant or Oil leaks	Crack or pin hole in tubing or brazed joints	Replace tubing or rebrase joint

International Support Channels

AFRICA

- **South Africa**
RAD Interface (Pty) Ltd
5 Bundo Road, Sebenza
P.O. Box 193
1610 Edenvale
Phone: 011 / 452 19 30
Telefax: 011 / 452 64 55

ASIA

- **Israel**
ATEKA LTD.
23, Hayetzira St., Kiryat Aryeh
Petach-Tikva 49512
Phone: 03 939 2303
Telefax: 03 924 3273
e-mail: marketing@ateka.co.il
- **Japan**
Naigai Energering Inc.
4-1-1 Takaida hon-dori
577-8551 Higasi-Osaka, City
Osaka
Phone: 06 / 6782 0570
Telefax: 06 / 6782 0511
e-mail: overseas@naigai-e.co.jp
- **Malaysia**
EITA Electric SDN. BHD.
Subang Jaya Industrial Estate
Block A, Lot 4, Jalan SS 13/7
47500 Petaling Jaya
Phone: 03 / 737 80 88
Telefax: 03 / 735 47 19
- **Singapore and rest of Asia**
PfannenberG GmbH
Asian Branch Office
371 Beach Road, # 14-02
Keypoint
Singapore 199597
Phone: 0065 295 68 66
Telefax: 0065 234 10 19
e-mail: asiasales@pfannenberG.com

AUSTRALIA

- **Australia**
Hagemeyer Electrical Group
456 Lower Heidelberg Road
Heidelberg, Victoria 3084
Phone: 03 / 95 01 80 00
Telefax: 03 / 95 01 80 29

EUROPE

- **Austria**
Otto PfannenberG GmbH
Austria Branch Office
Am Kaisermühlendamm 65/1
1220 Wien
Phone: 01 / 269 95 95
Telefax: 01 / 269 95 95 23
e-mail: johann.aigner@pfannenberG.com
- **Belgium**
Electro-Flandria n.v.-s.a.
Begoniastraat 6
9810 Nazareth - Eke
Phone: 09 / 385 51 11
Telefax: 09 / 385 64 30
e-mail: ef@online.be
- **Czech Republic**
Weidmüller, s.r.o.
Vídenská 340
252 42 Vestec
Phone: 02 / 44 00 14 00
Telefax: 02 / 44 00 14 99
e-mail: office@weidmueller.cz
- **Denmark**
CARLO GAVAZZI HANDEL A/S
Over Hadstenvej 42
8370 Hadsten
Phone: 89 60 61 00
Telefax: 86 98 15 30
e-mail: handel@gavazzi.dk
- **Finland**
Oy Klinkmann AB
Fonseenintie 3
00371 Helsinki
Phone: 09 / 540 49 40
Telefax: 09 / 541 35 41
e-mail: automation@klinkmann.fi
- **France**
PfannenberG France S.A.
4, Impasse Joliot Curie - BP 16
64110 Jurancon
Phone: 05 / 59 98 31 20
Telefax: 05 / 59 98 31 21
e-mail: david.pringhet@pfannenberG.com
- **Germany (Headquarters)**
Otto PfannenberG GmbH
Werner-Witt-Str. 1
D-21035 Hamburg
Phone: 040 / 73412 -0
Telefax: 040 / 734 12 - 101
e-mail: technical.support@pfannenberG.com
- **Great Britain**
PfannenberG (UK) Ltd.
Impress House
Mansell Road . Acton
London W3 7QH
Phone: 0208 / 743 88 80
Telefax: 0208 / 740 42 00
e-mail: mark.rosten@pfannenberG.com
- **Greece**
DIRAK-HELLAS E.P.E.
Ipsilantou Str. 93-95
18532 Piräus
Phone: 01 / 422 62 72
Telefax: 01 / 411 89 59
e-mail: dirak-hc@ote.net.gr
- **Hungary**
Trendelektro Kft.
Ulászóló u. 19
1114 Budapest
Phone: 01 / 209 30 29
Telefax: 01 / 209 30 29
e-Mail: trendelektro@freemail.hu
- **Italy**
PfannenberG Italia s.r.l.
Via La Bionda, 13
43036 Fidenza (PR)
Phone: 524 / 33 52 88
Telefax: 524 / 52 49 22
e-mail: mail@pfannenberG.it
- **Netherlands**
Elan Nederland
Fahrenheitstraat 42-44
3846 BN Harderwijk
Phone: 0341 / 43 25 25
Telefax: 0341 / 42 52 57
e-mail: elan@capitolonline.nl
- **Norway**
Hydro Aluminium Hydal AS
4265 Havik
Phone: 52 84 81 00
Telefax: 52 84 81 60
- **Poland**
Automatech Sp.z o.o.
ul. Ryzowa 84
05-815 Opacz Kolonia
Phone: 022-723 06 62
Telefax: 022-723 06 06
e-mail: postmaster@automatech.it.pl

- **Sweden**
Weidmüller AB
1) Skebokvarnsvägen 370
12450 Bandhagen
Phone: 08 / 727 23 00
Telefax: 08 / 727 24 80
2) Ebbe Lieberathsgatan 19
Box 16026
412 21 Göteborg
Phone: 031 / 706 37 00
Telefax: 031 / 706 37 15
3) Axel Danielssons v. 271
Box 31025
200 49 Malmö
Phone: 040 / 37 48 00
Telefax: 040 / 37 48 60
4) Fridhemsgratan 124
854 62 Sundsvall
Phone: 060 / 67 14 50
Telefax: 060 / 17 59 08
e-mail: Stockholm@Weidmuller.se
- **Switzerland**
Carl Geisser AG
Industriestraße 7
8117 Fällanden ZH
Phone: 01 / 806 65 00
Telefax: 01 / 806 65 01
e-mail: info@carlgeisser.ch
- **Turkey**
DIRAK ENDAKS
Endüstriyel Aksesuarlar LTD. STI
Perpa Ticaret Merkezi
80270 Okmeydani - Istanbul
Phone: 90 / 212 222 22 75
Telefax: 90 / 212 220 10 47
e-mail: endaks@superposta.com.tr

NORTH AMERICA

- **Canada, Mexico and United States**
PfannenberG Inc.
4087 Walden Avenue
Lancaster, N.Y. 14086
Phone: 716 / 685-68 66
Telefax: 716 / 681-15 21

SOUTH AMERICA

- **Argentina**
XANIVOR ELECTROEQUIPOS S.R.L.
Calle Gutenberg 1930
(1870) Avellaneda
Phone: 54 11 / 4228 4883
Telefax: 54 11 / 4228 4894
- **Brazil**
TASCO LTDA.
1) Av.Veread. José Angelo Biagioni,850
18550-000 Boituva - SP
Phone: 015 / 263 - 14 93
Telefax: 015 / 263 - 26 66
2) R. Américo Brasiliense,
2171-Cj.709
Chácara Santo Antonio
04715-005 Sao Paulo - SP
Phone: 011 / 5183 - 59 95
Telefax: 011 / 5183 - 40 86
e-mail: tasco@tascoltda.com.br

PfannenberG
ELECTRO-TECHNOLOGY FOR INDUSTRY



PfannenberG Inc.
4087 Walden Avenue
Lancaster, NY 14086
716-685-6866
716-681-1521 FAX
http://www.PfannenberG.com
e-mail: technical.support@pfannenberG.com