

1.

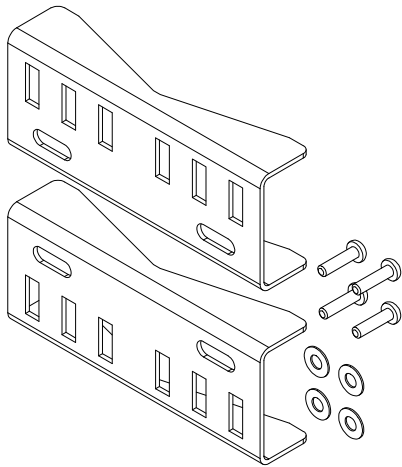

KITS ARE SUPPLIED WITH BRACKETS, #8 SELF TAPPING SCREWS, AND WASHERS.

NOTE: 1557B/BA USES ONE BRACKET

2.

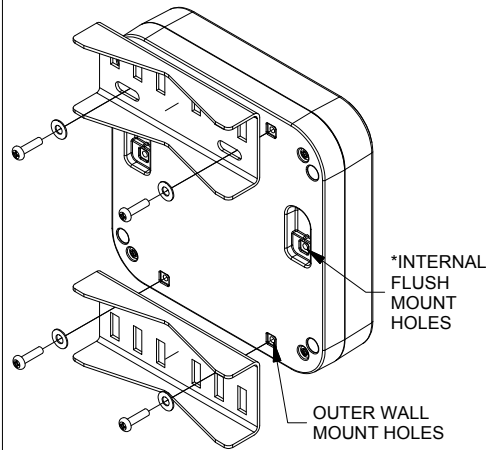

INSTALL BRACKET, WASHER AND SCREW TO THE OUTER WALL MOUNT HOLES,

\*FOR 1557B/BA USE INTERNAL FLUSH MOUNT HOLES.

4.

SMALL CLAMP (HCLAMP1), POLE DIAMETER RANGE 1.5in TO 7in (3.8cm to 17.8cm)  
LARGE CLAMP (HCLAMP2), POLE DIAMETER RANGE 1.5in TO 15in (3.8cm to 38.1cm)

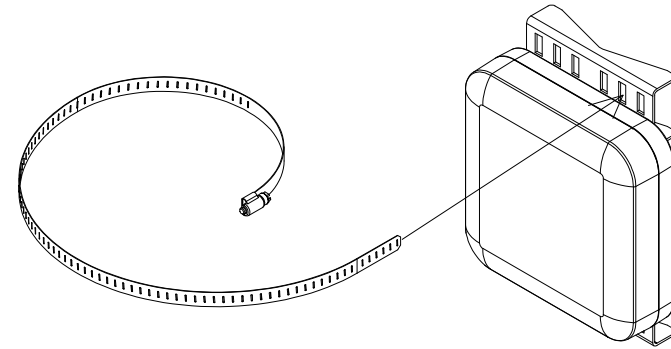

TO INSTALL BRACKETS ON POLE,  
START BY THREADING CLAMP THROUGH DESIRED SLOT

3.

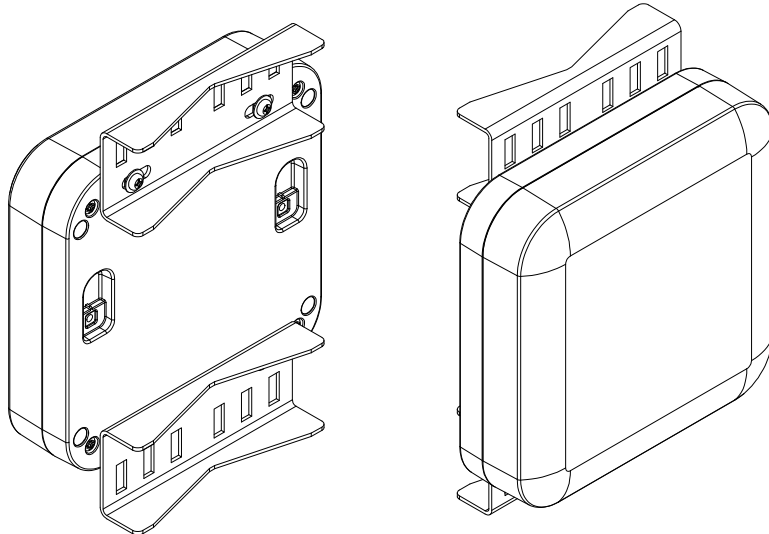

FOR #8 HARDWARE USE A #2 PHILLIPS HEAD.  
TORQUE ASSEMBLY TO 150 cN.m (13.5 lbf.in)

5.

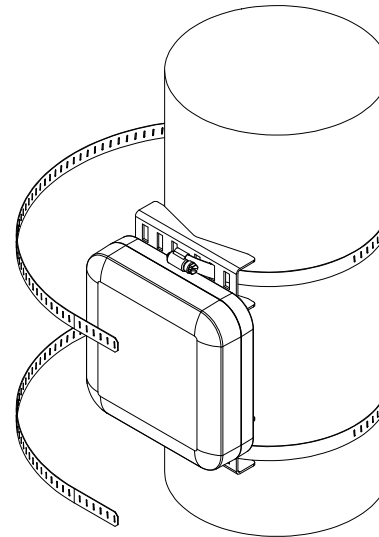

WRAP CLAMPS AROUND POLE  
AND THREAD THE CLAMPS  
BACK THROUGH BRACKET

6.

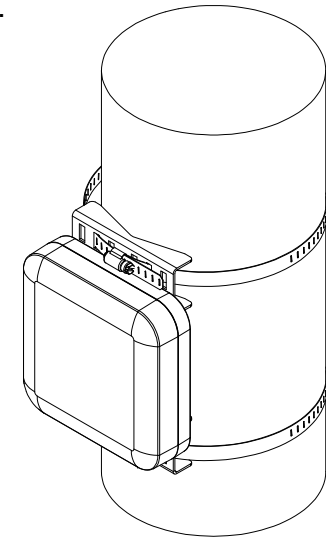

WHILE HOLDING ENCLOSURE  
AGAINST THE POLE, TIGHTEN  
CLAMPS WITH 5/16in (8mm)  
NUT DRIVE

 **HAMMOND  
MANUFACTURING.**  
1557 POLE MOUNT  
INSTRUCTIONS  
[www.hammondmfg.com](http://www.hammondmfg.com)