

### Floor Mounting (Required for Zone 4 Compliance)

The cabinet must be anchored to the floor at each corner using the hardware supplied (C4K-Z4), **casters must be removed**. Drill (4) 3/8" holes minimum 3.88" deep and set anchor bolts with a 3.50" embedment at required locations.

#### Recommended Anchor Bolt Location

**\*USE CABINET FRAME AS TEMPLATE\***

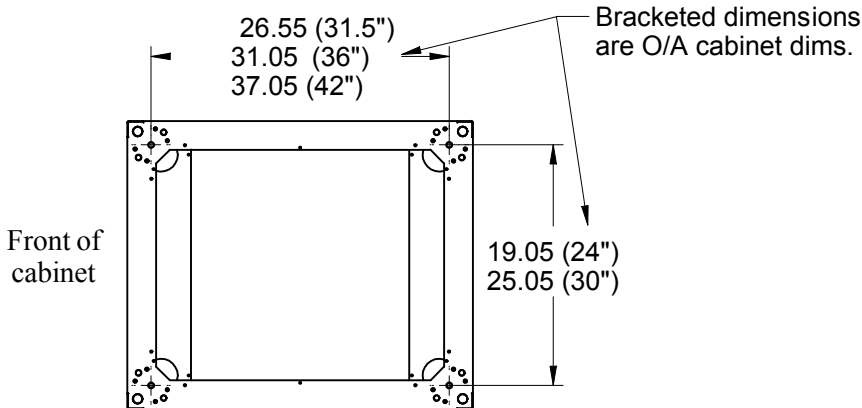

BOTTOM VIEW OF C4 CABINET

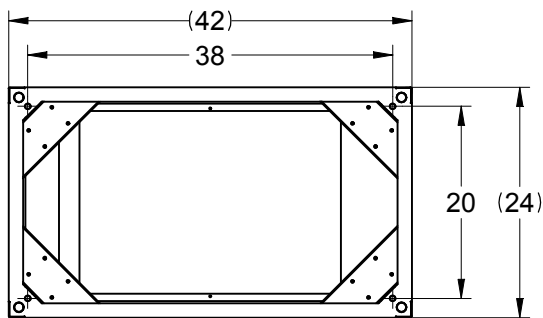

BOTTOM VIEW OF DC100 CABINET

C4 cabinet frame shown

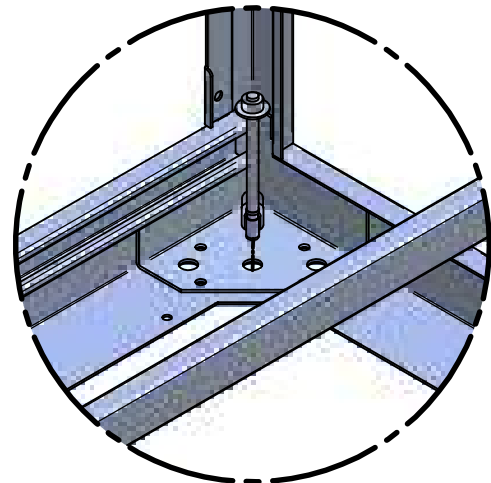
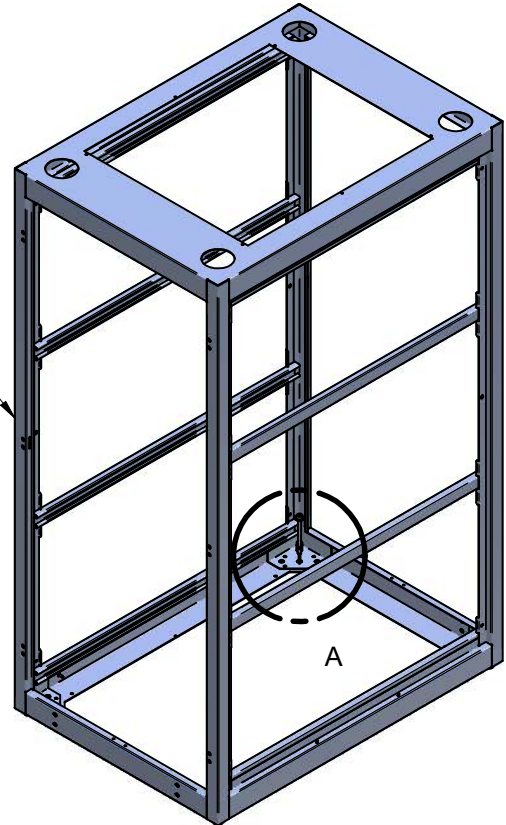

DETAIL A

The seismic loading of the C4 cabinet series was determined in accordance with the Uniform Building code 1997 (UBC 97) for Seismic Zone 4.

The C4 cabinet series was found structurally adequate to safely resist Seismic Zone 4 earthquake loads when supporting 1,000 lb of equipment. The center of mass of the equipment must be no higher than the mid-height of the cabinet frame.

TOOL BOX



Drill

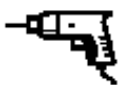

Rubber Mallet



Socket Set



**HAMMOND**  
**MANUFACTURING™**  
ELECTRONICS GROUP

visit our website @ [www.hammondmfg.com](http://www.hammondmfg.com)